

HEAVY DUTY FLOODED BATTERY

68044 (12V180Ah)



CHARACTERISTICS

| Item | Specifications | |
|--------------------------------|-------------------|----------------------|
| Nominal Voltage | 12V | |
| Nominal Capacity (20HR) | 180Ah | |
| Reserve Capacity | 360min | |
| Cold Cranking Amps@0°F (-18°C) | 1000A | |
| Dimension | Length | 518mm (20.4inches) |
| | Width | 274mm (10.8inches) |
| | Height | 236.5mm (9.31inches) |
| Approx Weight | 51.4kg (113.3lbs) | |
| Terminal | 1 | |
| Cell layout | 3 | |
| Hold-Down | B0 | |
| Case | Black-PP Material | |
| Cover | Black-PP Material | |
| Handle | TS8 | |

APPLICATIONS

- Commercial vehicle start
- Engine start

GENERAL FEATURES

- High capacity and high CCA
- Maintenance-free
- High vibration resistance
- Strong lead-calcium alloy grids for great corrosion resistance
- High strength PP case and cover no need be worried about breakage
- OE quality certification

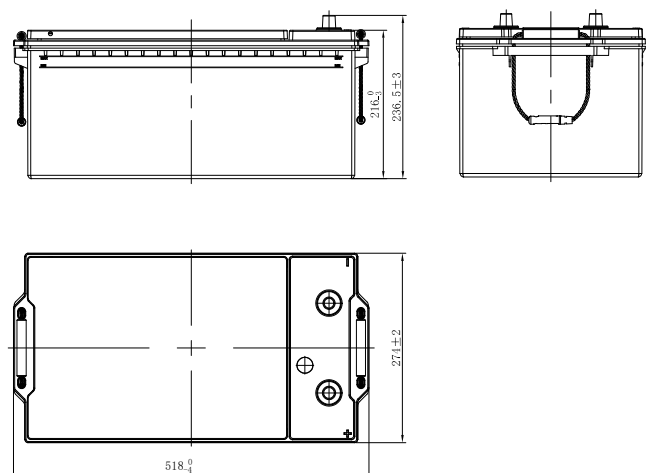
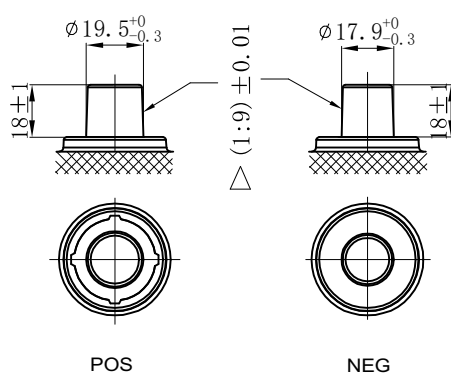

*Values are subject to variation of +/- 5% in normal manufacturing processes.

Leoch International Technology Ltd.
www.leoch.com

Leoch Batteries Pte Ltd
www.leoch.sg

Leoch Battery Corporation
www.leochamericas.com

Leoch Europe S.A.
www.leoch.eu